

INSIDE CORNER / COVE TRIM # P0270

CEILING INSTALLATION

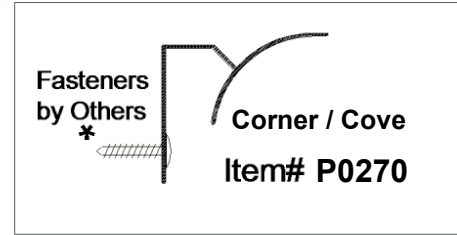
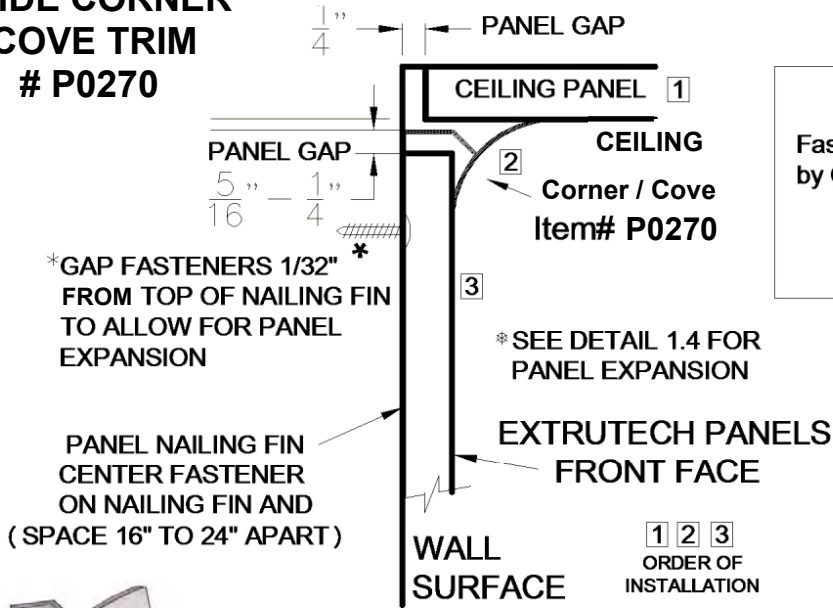

*GAP FASTENERS 1/32" FROM TOP OF NAILING FIN TO ALLOW FOR PANEL EXPANSION

*SEE DETAIL 1.4 FOR PANEL EXPANSION

PANEL NAILING FIN CENTER FASTENER ON NAILING FIN AND (SPACE 16" TO 24" APART)

1 2 3
ORDER OF INSTALLATION

Inside Corner / Cove Trim Cross Section

CEILING TRIM DETAIL 3.3-3 FOR VERTICAL PANEL INSTALLATION

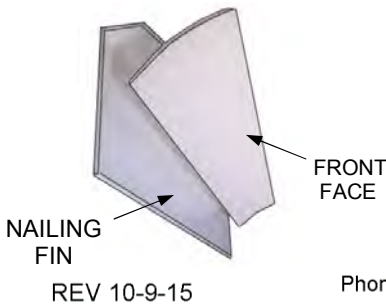

EXTRUTECH PLASTICS, INC.

5902 West Custer Street Manitowoc WI 54220
Phone 920-684-9650 | Toll Free 888-818-0118 | Fax 920-684-4344
www.epiplastics.com



J-TRIM # P0100

FLOOR INSTALLATION

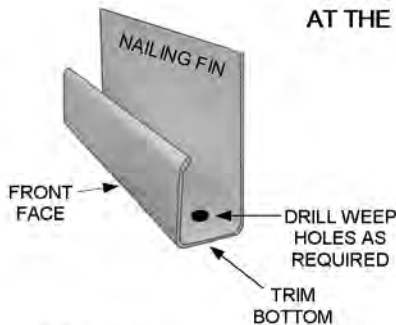
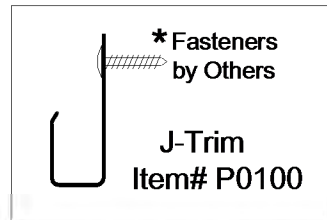
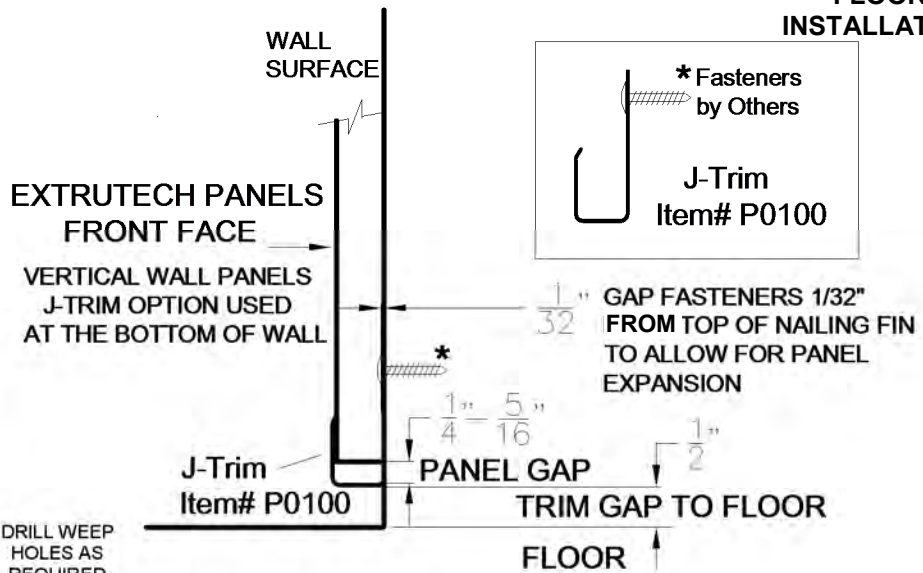

J-Trim Cross Section FOR VERTICAL PANEL INSTALLATION FLOOR TRIM DETAIL 4.1-2



EXTRUTECH PLASTICS, INC.

5902 West Custer Street Manitowoc WI 54220
Phone 920-684-9650 | Toll Free 888-818-0118 | Fax 920-684-4344
www.epiplastics.com



**FLOOR
INSTALLATION**

**INSIDE CORNER
/ COVE TRIM
P0270**

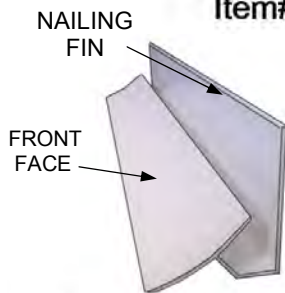
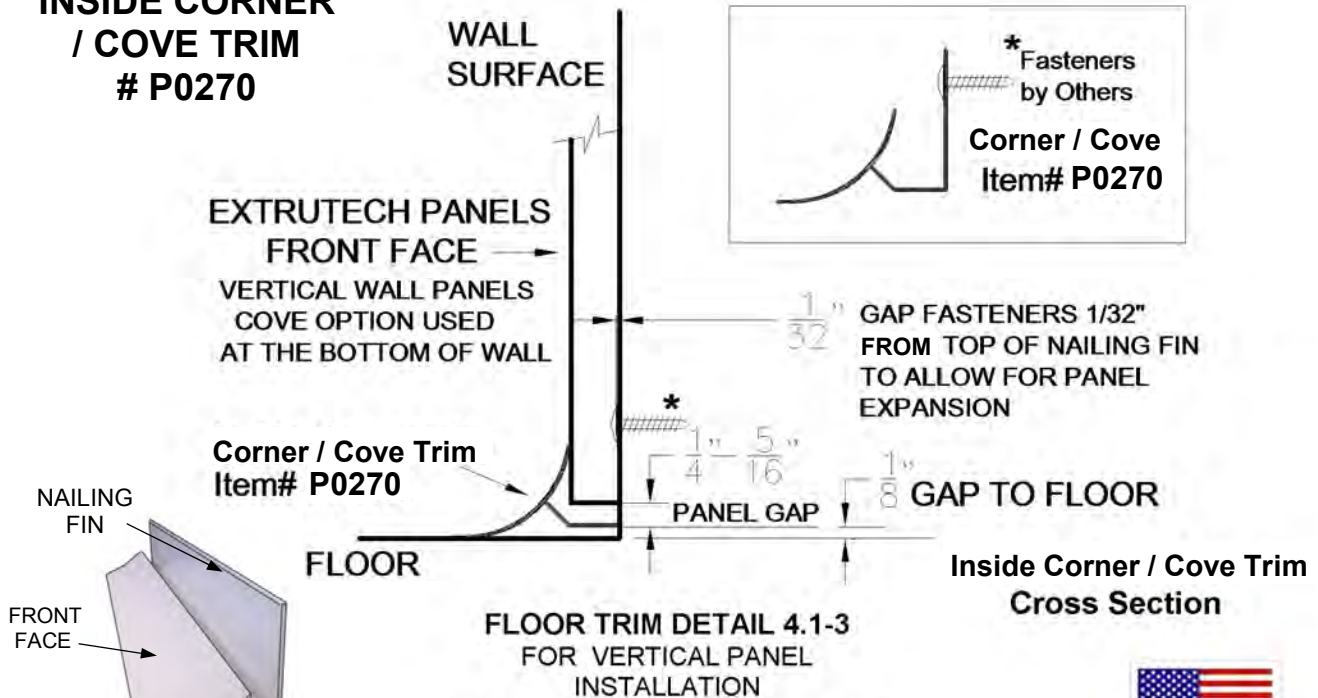

REV 10-9-15

EXTRUTECH PLASTICS, INC.

5902 West Custer Street Manitowoc WI 54220
Phone 920-684-9650 | Toll Free 888-818-0118 | Fax 920-684-4344
www.epiplastics.com



**J TRIM
ITEM # P0100**

**CEILING
INSTALLATION**

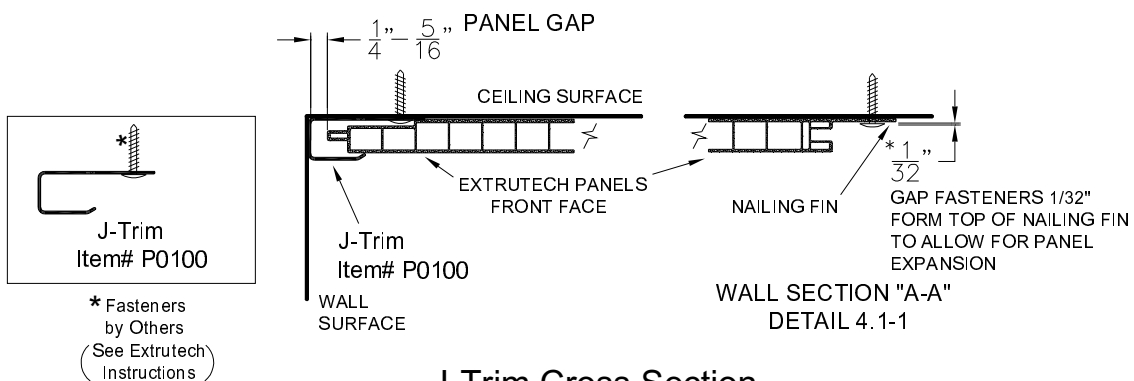

* Fasteners by Others
(See Extrutech Instructions)

**J-Trim Cross Section
FOR CEILING PANEL
INSTALLATION**

DETAIL 4.1-2

REV 6-15-16



PAGE 2

EXTRUTECH PLASTICS, INC.

5902 West Custer Street Manitowoc WI 54220
Phone 920-684-9650 | Toll Free 888-818-0118 | Fax 920-684-4344
www.epiplastics.com



OUTSIDE CORNER # P0220

WALL or CEILING
INSTALLATION

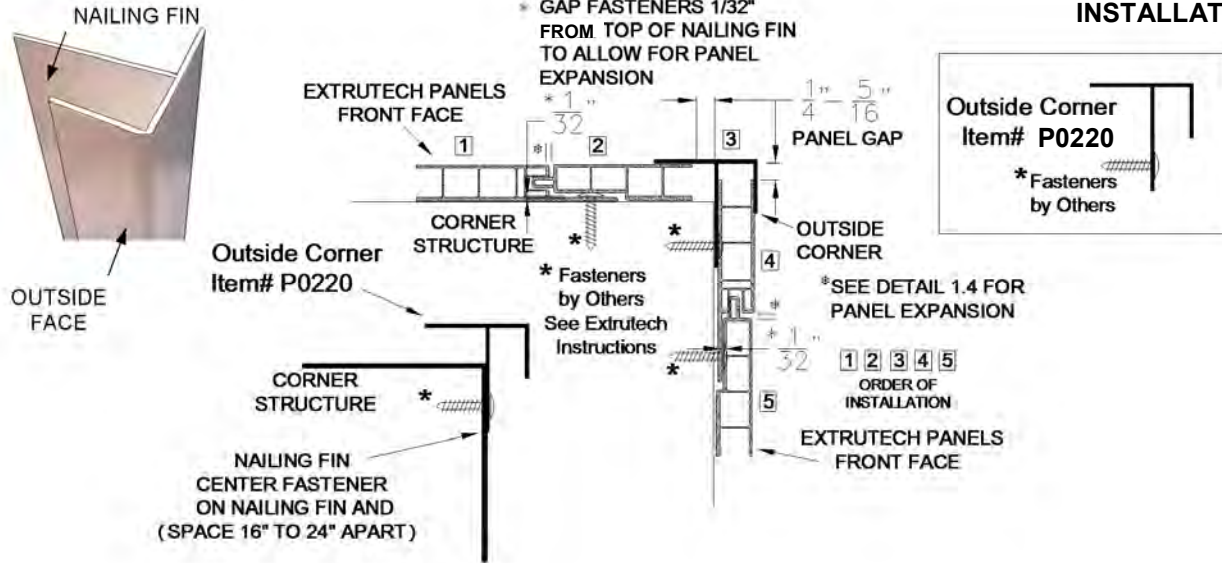

**CORNER TRIM DETAIL 4.1-2
FOR VERTICAL PANEL
INSTALLATION**

**Outside Corner Trim
Cross Section**

REV 10-9-15



EXTRUTECH PLASTICS, INC.

5902 West Custer Street Manitowoc WI 54220
Phone 920-684-9650 | Toll Free 888-818-0118 | Fax 920-684-4344
www.epiplastics.com



BULLNOSE OUTSIDE CORNER # P0290

WALL CORNER
INSTALLATION

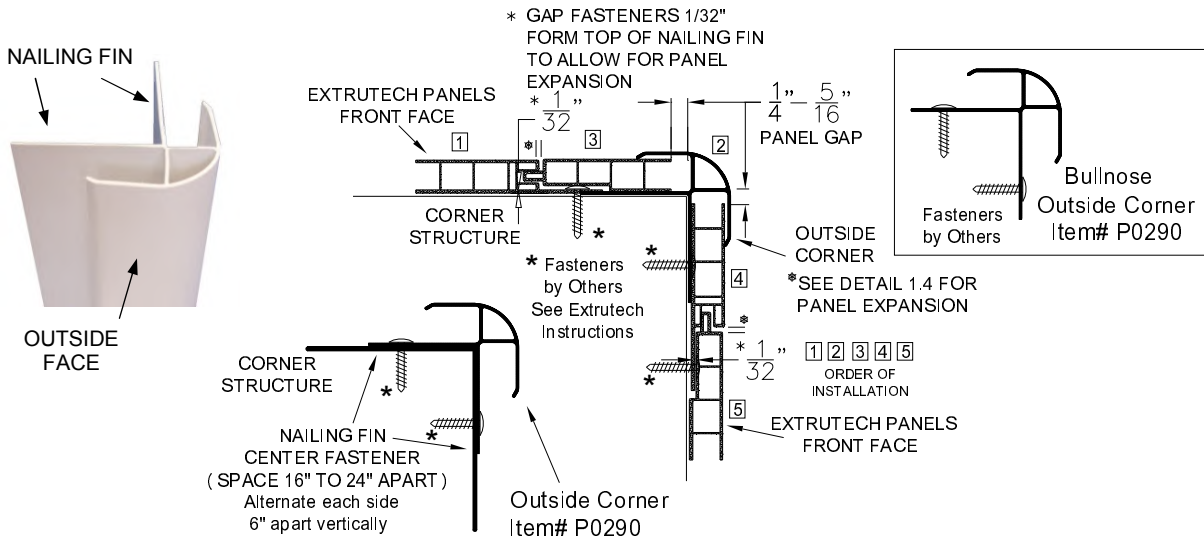

**CORNER TRIM DETAIL 5.1-1
FOR VERTICAL PANEL
INSTALLATION**

**Bullnose Corner Trim
Cross Section**

REV 6-15-16



EXTRUTECH PLASTICS, INC.

5902 West Custer Street Manitowoc WI 54220
Phone 920-684-9650 | Toll Free 888-818-0118 | Fax 920-684-4344
www.epiplastics.com



DOUBLE J RIDGE TRIM # P0140

CEILING INSTALLATION

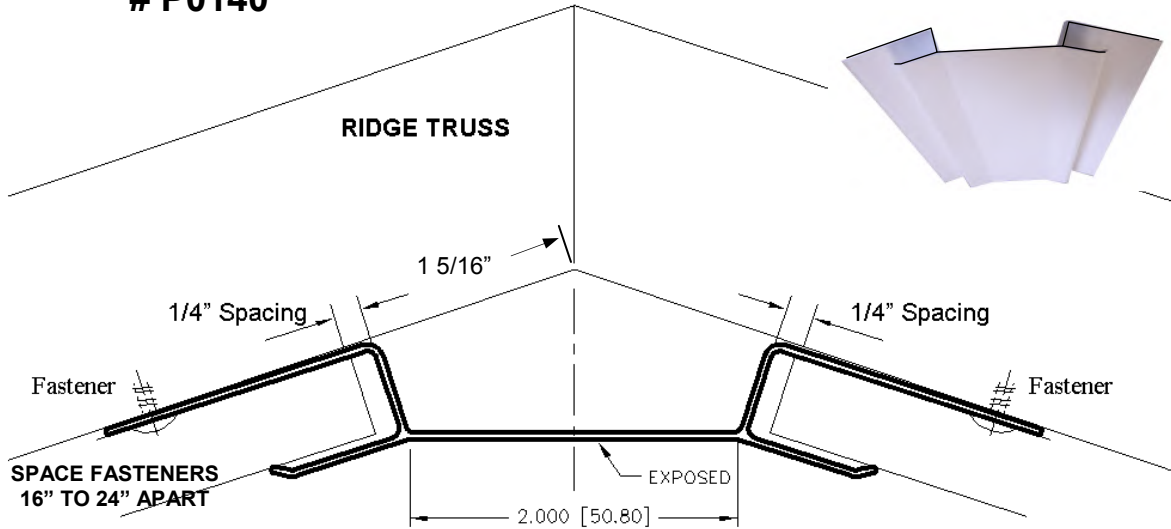

J-Ridge Cross Section



EXTRUTECH PLASTICS, INC.
 5902 West Custer Street Manitowoc WI 54220
 Phone 920-684-9650 | Toll Free 888-818-0118 | Fax 920-684-4344
www.epiplastics.com

45 DEGREE CORNER ITEM # P0145

CEILING INSTALLATION

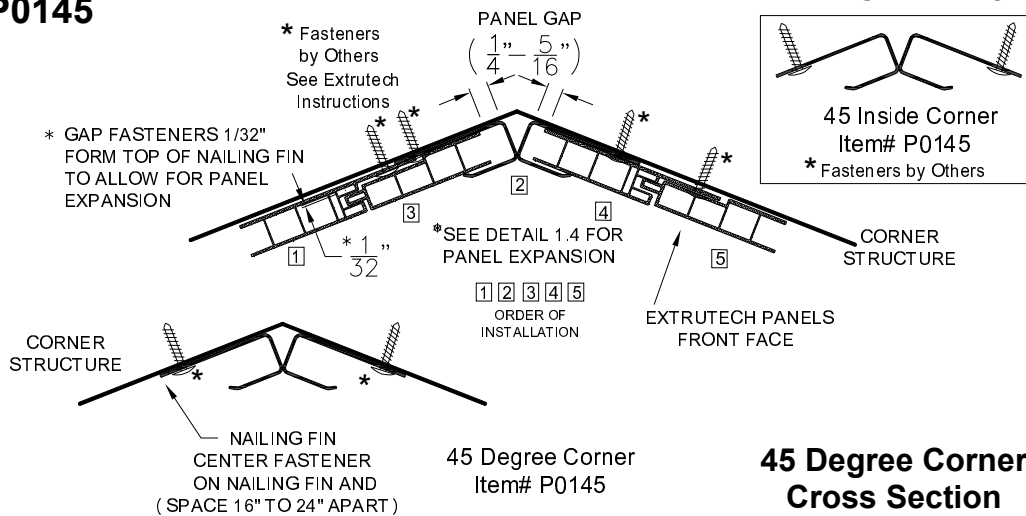

REV 3-30-17



PAGE 4

EXTRUTECH PLASTICS, INC.
 5902 West Custer Street Manitowoc WI 54220
 Phone 920-684-9650 | Toll Free 888-818-0118 | Fax 920-684-4344
www.epiplastics.com



**2 x 2 CORNER
P0250**

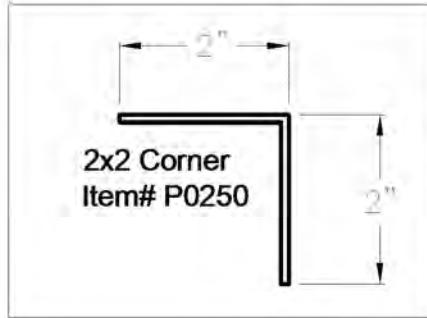
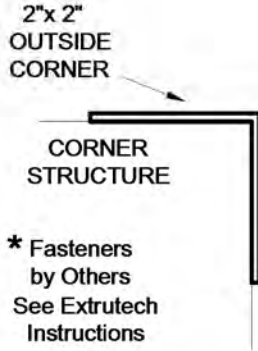

**WALL CORNER
INSTALLATION**



**2x2 Corner Trim
Cross Section**

REV 10-9-15



**2x2 CORNER TRIM DETAIL 4.1-2
EXTRUTECH PLASTICS, INC.**

5902 West Custer Street Manitowoc WI 54220
Phone 920-684-9650 | Toll Free 888-818-0118 | Fax 920-684-4344
www.epiplastics.com



**3 x 3 CORNER
P035016**

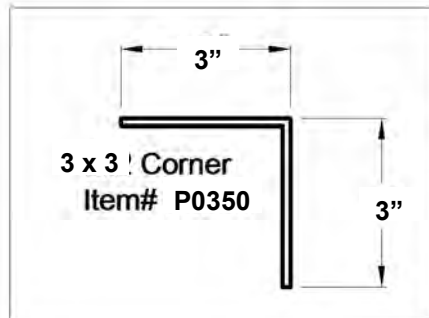
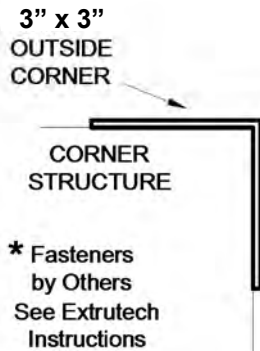

**WALL CORNER
INSTALLATION**



**3 x 3 Corner Trim
Cross Section**

REV 10-9-15



**3 x 3 CORNER TRIM DETAIL 4.1-2
EXTRUTECH PLASTICS, INC.**

5902 West Custer Street Manitowoc WI 54220
Phone 920-684-9650 | Toll Free 888-818-0118 | Fax 920-684-4344
www.epiplastics.com



**WIDE H-BAR
P0231**

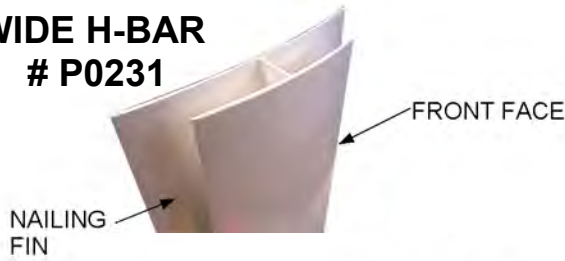

**WALL or CEILING
INSTALLATION**

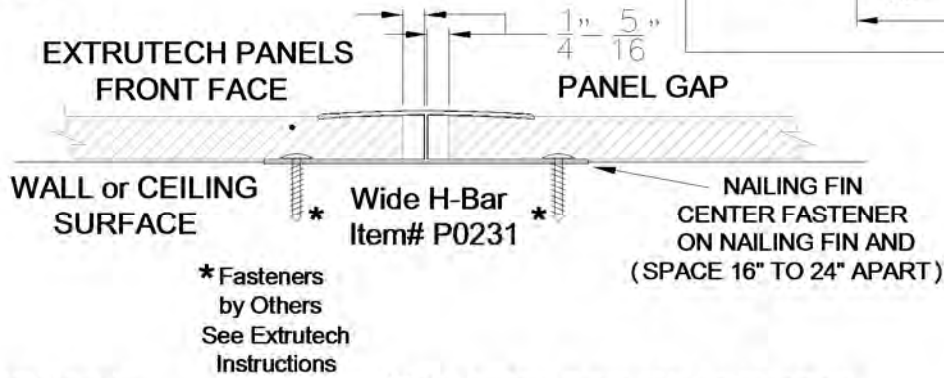
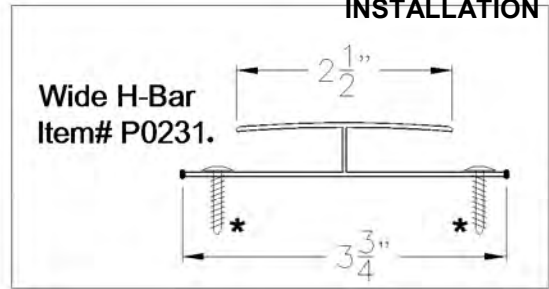

* Fasteners
by Others
See Extrutech
Instructions

REV 10-9-15



Wide H-Bar Trim Cross Section

EXTRUTECH PLASTICS, INC.

5902 West Custer Street Manitowoc WI 54220
Phone 920-684-9650 | Toll Free 888-818-0118 | Fax 920-684-4344
www.epiplastics.com



**CROWN CAP
P0243**

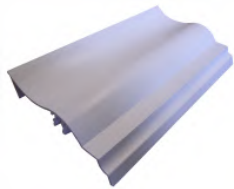

**CROSS SECTION
CEILING**

**CEILING
INSTALLATION**

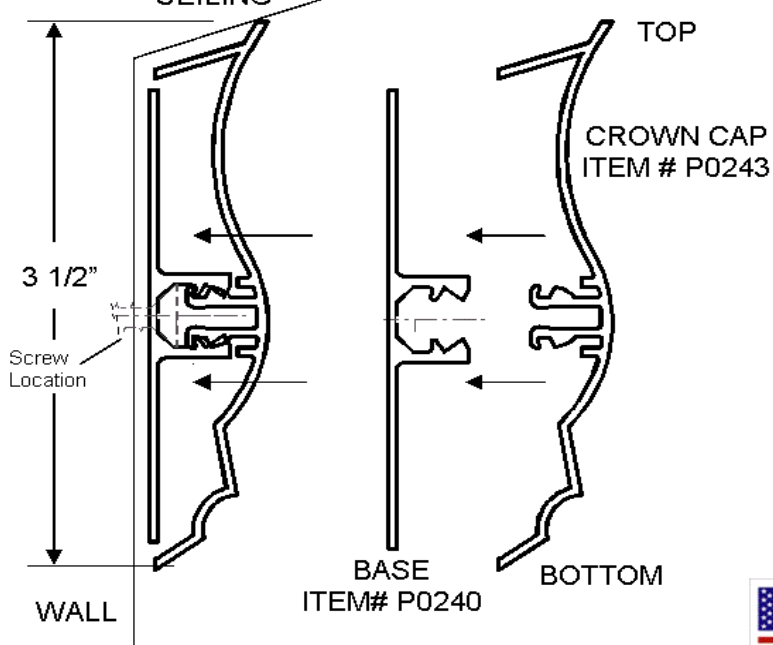

Crown Cap Cross Section



ITEM# P0240 & P0241

3" CAP TWO PART H-BAR

WALL or CEILING
INSTALLATION

WALL & CEILING EXPANSION JOINT CONNECTOR

Install at 16' intervals, between panels with 1/2" gap between edge of panel and side of H-Bar base to allow for the expansion of the panels.

Fasten ends of panels to each side of P0241 BASE as shown

NOTE: ALL PANELS NEED TO BE ALLOWED TO EXPAND

NOTE: Cap (P0240) Teeth Face to Outside

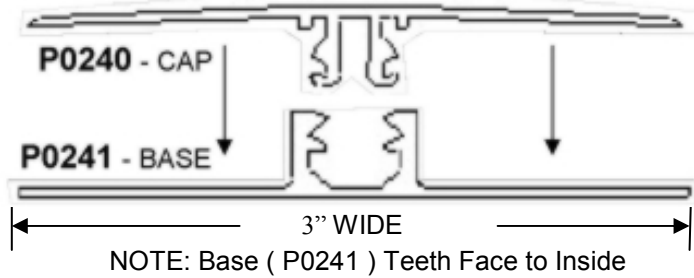

P0240 - CAP

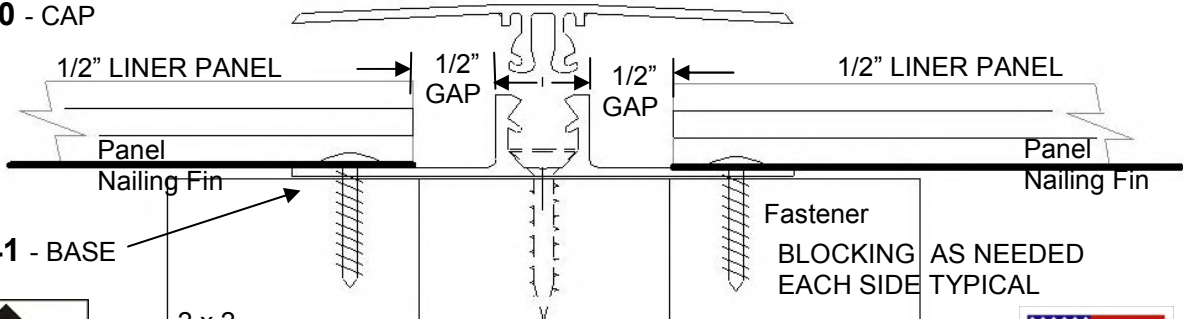

EXTRUTECH PLASTICS, INC.
 5902 West Custer Street Manitowoc WI 54220
 Phone 920-684-9650 | Toll Free 888-818-0118 | Fax 920-684-4344
 www.epiplastics.com



ITEM# P0540 & P0241

5" CAP TWO PART H-BAR

WALL or CEILING
INSTALLATION

WALL & CEILING EXPANSION JOINT CONNECTOR

Install at 16' intervals, between panels with 1/2" gap between edge of panel and side of H-Bar base to allow for the expansion of the panels. Fasten ends of panels to each side of P0241 BASE as shown

NOTE: ALL PANELS NEED TO BE ALLOWED TO EXPAND

NOTE: Cap (P0540 - 5" CAP) Teeth Face to

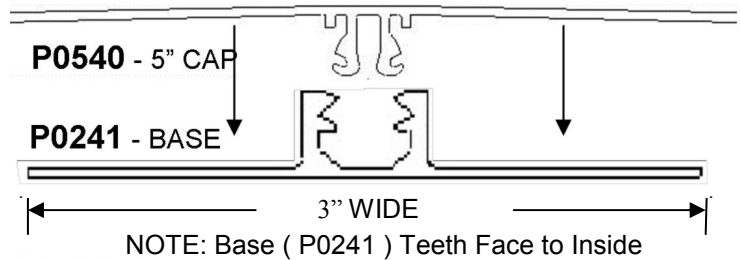

P0540 - CAP

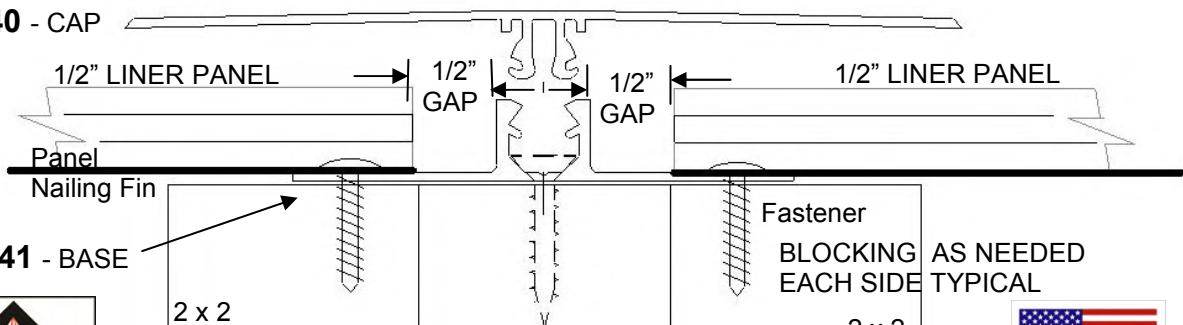

PAGE 7

EXTRUTECH PLASTICS, INC.
 5902 West Custer Street Manitowoc WI 54220
 Phone 920-684-9650 | Toll Free 888-818-0118 | Fax 920-684-4344
 www.epiplastics.com



DRIP EDGE # P0260

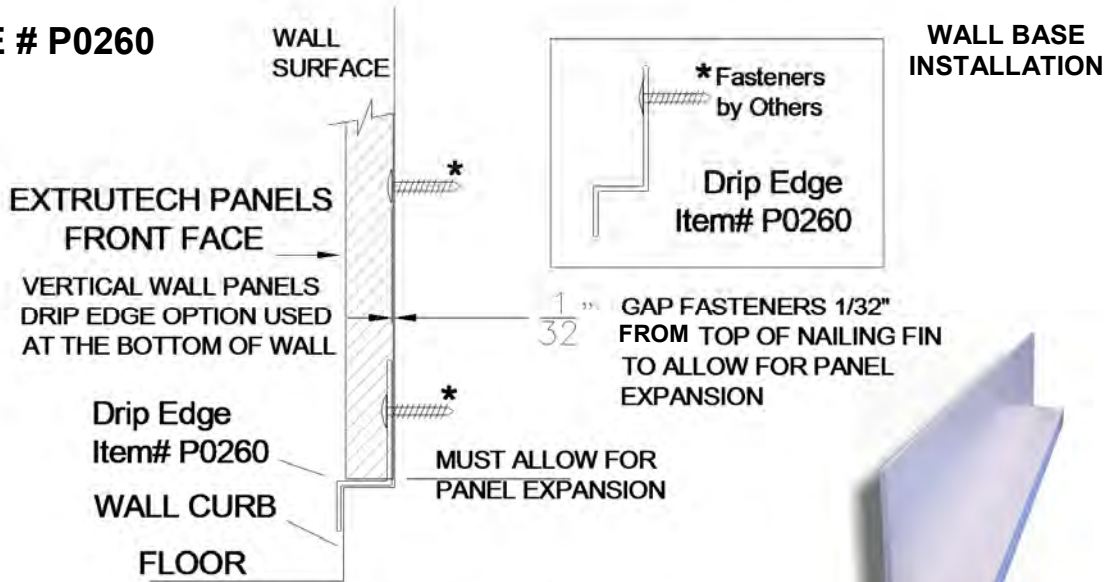

Drip-Edge Trim Cross Section
FOR VERTICAL PANEL
INSTALLATION
FLOOR TRIM DETAIL 4.1-4

REV 10-9-15



EXTRUTECH PLASTICS, INC.

5902 West Custer Street Manitowoc WI 54220
Phone 920-684-9650 | Toll Free 888-818-0118 | Fax 920-684-4344
www.epiplastics.com



Part # WM600

6" HIGH BASE BOARD

- Available Colors: WHITE
- Available Lengths: 12', & 16' Feet.
- Material: RIGID FOAMED PVC

The 6" Base Board has a overall height of 6" and base width of 1". Trim can be cut with a standard power miter saw using a fine-toothed blade. Fastens with small head trim screw two feet on center and construction adhesive along the back side and bottom.

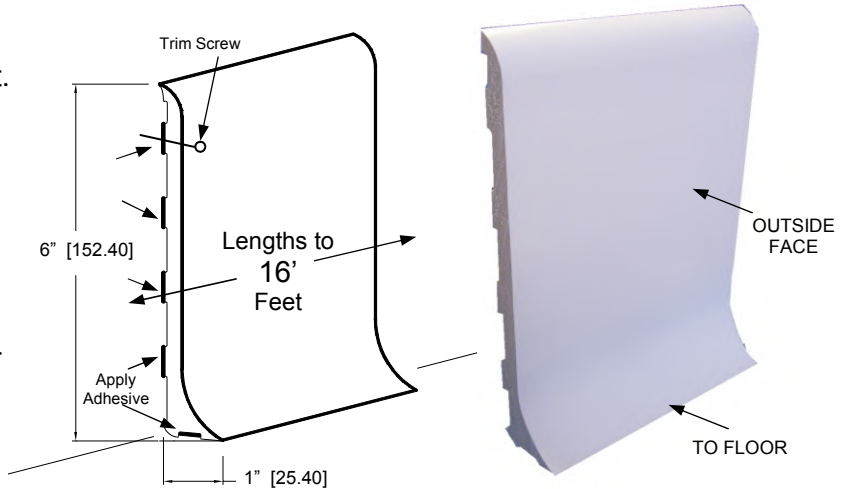

6" BASE BOARD DETAIL 6.00

EXTRUTECH PLASTICS, INC.

5902 West Custer Street Manitowoc WI 54220
Phone 920-684-9650 | Toll Free 888-818-0118 | Fax 920-684-4344
www.epiplastics.com

REV 10-27-16

